



eBook Distribution Guidelines

Lulu Publishing Guide
Copyright © 2011 Lulu Press
All rights reserved.

This work is licensed under the Creative Commons Attribution-ShareAlike 3.0 Unported License. To view a copy of this license, visit <http://creativecommons.org/licenses/by-sa/3.0/> or send a letter to:
Creative Commons
171 Second Street, Suite 300
San Francisco, California, 94105, USA.

www.lulu.com

Introduction

We know you are excited about publishing and selling your eBook to a whole new market of readers who own eReading devices and applications around the world. This document will help walk you through some essential guidelines and tips to ensure your work is in tiptop shape to be published. Please note that it is important to read this document in its entirety. If your title does not meet our distribution guidelines, we will not be able to accept it for distribution.

Is my content ready to be an eBook?

It is important to note that there are differences between the way print books and eBooks need to be formatted. Since the technology is still evolving, each platform and format can portray eBook content in a slightly different way. The formatting tips below will help provide a more robust experience for your readers.

1 Crisp, High-quality Images & Cover Art

We want to ensure that your images look great on any eReader, computer or digital device. If you decide to include images in your eBook, we can only accept high-resolution, three color, RGB (red, green, blue) formatted pictures. Four color, CMYK (cyan, magenta, yellow, key black) images cannot be accepted.

2 Fonts

We've all been there, you find a cool font that you're just in love with and think conveys your book's "personality." But it is important to remember that not all devices can display all fonts the same way. It's best to stick with standard fonts (like Times New Roman or Arial) to ensure that your text is conveyed clearly across formats, devices and applications.

3 Page Based Formatting

EPUB formatted eBooks, which are needed for distribution, are made up of flowable text that adjusts based on the screen or device the reader is using. Unlike their print counterparts, eBooks don't use page-based formatting. Page numbers, headers or footers don't exist in eBooks, so don't use them.

4 Paragraph Separation

Proper paragraph breaks are essential for a great eBook, otherwise paragraphs will bump into each other and your readers won't know where one stops and another starts. Make sure your paragraphs are either in a block format or first line indent format, so your readers will be able to enjoy your works on any of their favorite devices.

What do I need to publish my eBook?

An EPUB

An EPUB (short for electronic publication) file is the most universally accepted eBook file format for eReading device everywhere. The EPUB format allows text to re-flow and can accommodate the capabilities of most eBook readers. This means readers can change the text size, font, or the orientation of your eBook to best fit their needs.

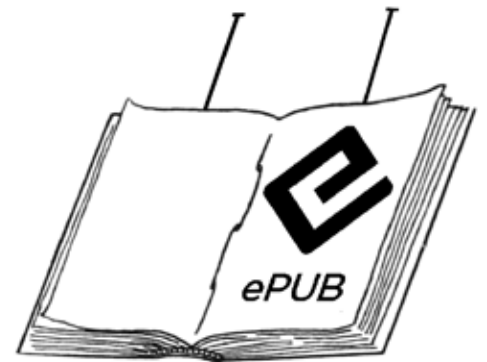

Though you can sell your title as a PDF on the Lulu Marketplace, our retail channels only accept books formatted according to the EPUB 2.0.1 standard. If you don't have an EPUB, you can [create one yourself](#), or let our team of conversion specialists help you get your eBook in tip top shape. Visit our services page for a [more information](#).

An ISBN

ISBN 90-225-3192-9



You ever notice that long string of numbers on the back of a book near the barcode? That's called an ISBN and is what every single retail channel uses to list your book and track your sales. You can get a free ISBN from Lulu when you publish through our eBook Wizard, or bring one you've purchased on your own. And if you prefer not to have an ISBN, you won't be able to distribute your title to our retail partners, but you can still publish your title on the Lulu Marketplace.

Cover Art

The cover of your eBook will be the first thing many of your readers will see. It's kind of like a first impression or welcoming handshake. And an eye-catching cover can often be just the thing to turn a casual looky-loo into your biggest fan. Luckily, Lulu makes cover design a snap. With our cover tools, you can upload an RGB cover designed by yourself or one of our skilled cover design artists, or you can pick from one of hundreds of our pre-made templates and themes. We've made sure to provide tons of options to make your work really stand out.



Complete and Accurate Metadata

Simply put, metadata is the who, what, when, and where of your eBook. Items such as your title, author name(s), description, etc. are all types of metadata and are what most retailers use to appropriately list and categorize your content. Metadata is also one of the main reasons eBooks get rejected for distribution; it must be accurate so those searching for your project within a catalog can find it.

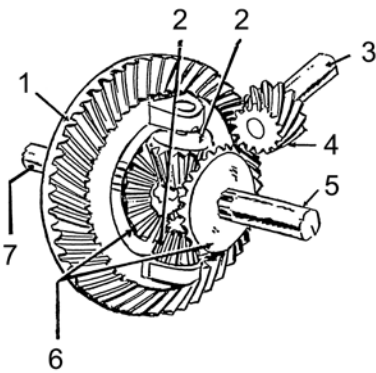

Retail Distribution Requirements

In order for your readers to have the best possible experience with your eBook and to ensure its eligibility for distribution, it is critical that you follow our list of eBook retail distribution requirements. If your content does not meet any of the following requirements, it will not be accepted for distribution to our retail partners. But don't fret, we've outlined everything you need below to help you on your way.

Showstoppers - Things You Must Avoid

Advertising – Please do not include advertisements in your book or in your description as these are not allowed. Besides, your readers deserve to enjoy your content without any distractions.

Pricing – We cannot accept eBooks for distribution that list prices anywhere on the cover, in the description, or in the eBook itself. This guideline ensures that you have the flexibility to change the price whenever you wish, without requiring you to resubmit a new EPUB.

URLs – We cannot accept eBooks with URLs in in cover, title or description. So don't do it!

Extras – Unfortunately, eReaders that can deliver extras like a poster, CD, or little stuffed bear haven't been invented yet, if you mention extras that come with the print version of your book, remember to remove those references in your eBook. Otherwise your title cannot be accepted for distribution.

Paper – Remember, your eBook will not be printed - make sure people can enjoy it without a pen. That means no workbook or notes pages. Likewise, there's no need to mention where the book is printed, or on what paper.

Language – Though we hope to be able to accept other languages in the future, currently we are only able to accept English language content.

Title and Description

- Your eBook's title must match everywhere: in the metadata, on your cover, and on the book's title page.
- Subtitles are particularly important for differentiating multiple books in a series that share the same title.
- Do not use font sizes in the description (Example: ``).
- Titles and Subtitles need to be correctly capitalized. The first letter of all words in the title and subtitle should be capitalized, except for the following words: a, an, and, for, from, of, or, the, to. The first and last word of the title and subtitle should always be capitalized.
- Do not use HTML lists in description.
- Titles beginning with articles should display properly. EX: A Tale of Two Cities, not Tale of Two Cities, A.
- You must have a valid description. (Ex: Do not use the title).
- For more title/subtitle help, visit the [Lulu blog](#).

Author Name

- Author names must be correctly spelled and formatted.
- Author names must match everywhere: metadata, cover, and book's title page.
- First name should appear before the last name (Example: Bob Young, not Young, Bob).
- Author names must also be correctly capitalized.
- Do not enter author names in all capitals.
- All main authors who are equally credited on the cover art and eBook must be entered individually. If a book has more than one author, do not omit an author or combine both authors in one field. This is called a “compound artist.” Compound artists prevent retail channels from identifying individual authors. Customers then can't find the book when searching for an individual author.

Content and Genres

- All content must comply with [Lulu's membership agreement](#).
- Illegal content will not be accepted.
- Retail Channels reserve the right to select the genre for an eBook. The most appropriate genre will be chosen to aid the customer in finding the eBook. Ensure the best genre is chosen, by selecting the correct category in the eBook Wizard.
- Erotica or adult content must be categorized appropriately.
- Language must be in English.
- Public domain content will only be submitted to U.S. Retail Distributors.

ISBN

- You cannot reuse an ISBN from another book (printed or eBook).
- Your eBook ISBN must be owned by you or Lulu.com.
- You cannot use the ISBN you get from Lulu.com with another publisher or company.

Other Technical & Formatting Considerations

The following formatting and technical issues may also cause your title to be rejected for distribution.

- Cut off text.
- Overlapping text or images.
- Unreadable charts, tables, and maps.
- Missing, incomplete, unreadable, or inaccurate Table of Contents. NCX must be accurate.
- Incomplete EPUB file (Example: missing chapters).
- Bad transcoding in the EPUB file. This is commonly caused from improperly encoding the text in UTF-8 or UTF-16 format. (Example: Äù ,Äô ,Äú ,Äç displaying instead of quotes, apostrophes, or bullets).
- Page numbers in eBook.
- Headers and footers in eBook.
- Improperly formatted text (Ex. Garbled or improperly spaced text).
- Images not saved in RGB format.

A Final Check

Before you upload and hit “Save & Finish,” take one last look to make sure you have all done all of the following:

- You have all the necessary components to publish and distribute your eBook – a properly formatted EPUB, an ISBN, cover art, and complete and accurate metadata.
- You have tested your EPUB to make sure it is working, every link works, and the images it contains are top quality. Here are a couple of places you can check your file:

To view EPUB files

<http://www.adobe.com/products/digitaleditions/> (Windows, Mac OS X)

<http://www.lexcycle.com/> (iPhone®, iPod Touch®)

<http://www.apple.com/ipad> (iPad®)

To validate that EPUB files are correctly formatted

<http://www.threepress.org/document/epub-validate/>

<http://code.google.com/p/epubcheck>

- You have reviewed our eBook retail distribution requirements and ensured that your content meets all of these requirements.
- Take a moment....breathe a deep breath, and pat yourself on the back. You’ve taken a big step towards selling more books and reaching more readers than ever before.

What's Next?

Once you have submitted your title, our team of quality assurance specialists will review it to ensure it meets the guidelines and requirements laid out in this document. If your title bounces back from distribution for any reason, we'll let you know so you can make changes and resubmit. If your title is approved, we'll send it to our retail distribution partners immediately. You will usually see your title live on their retail stores about 2 business days after it is sent. Please note that our partners still reserve the right to refuse some content.

With our handy set of guidelines, you should be ready to publish and sell your eBook and can be confident it looks its best. We look forward to your continued success on Lulu.com and our growing network of retail partners.